

Boomer S2

Robust face drilling rig with
a coverage area up to 56 m²



Robust performance in a small package

The Boomer S2 is our smallest mining and tunneling rig with intelligent control, now tougher – and smarter than ever. All aspects of the rig, from the rock drill to the carrier have been improved.

⊕ Main benefits

Increased safety thanks to ROPS and FOPS certified cabin

Unmatched productivity in its class thanks to increased durability, faster drilling and overall strengthened components

Increased robustness thanks to stronger booms, long life drill platform and stronger chassis



With the unique safe bolting boom function there is no need to step in front of the rig under unsupported rock during bolt installation. All service points are accessible from ground level.



The control system is easy to learn and maximizes the performance with faster boom positioning and optional fully automated drilling.



The new feeds feature interchangeable drill steel bushings which means that you can use either rubber or steel bushings without changing holder.



ROPS and FOPS certified cabin for added safety and lower sound level in the cabin

1 000 hours recommended service interval and up to 15% faster drilling than closest competitor

All hydraulic hoses connects to the back, and a new hose drum with separate grooves for each hose results in superior hose life

Fast and precise positioning, durable and light-weight with possibility for steel or rubber bushings on the same feed

The new BUT S booms are faster, stronger, gives better visibility, greater coverage area and far less maintenance

The filtration package provides longer life on rock drills, hydraulic valves and pumps which leads to lower running costs

Carrier improvements include new frames with stronger waist, faster tramming, less breakdowns and new stronger diesel engines up to stage 4F

Where automation meets robustness

When designing this drill rig, we focused on robustness, automation and performance. The outcome is a solid workhorse that will push the productivity through the roof.

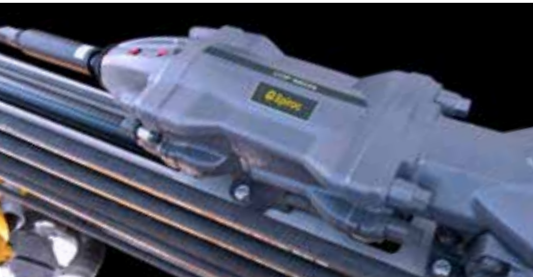

+ COP MD20 is more productive and more robust

The new generation of rock drills are more durable than ever, with improved penetration rate, drill steel economy, up to 30% less RDT consumption, less vibrations, higher hydraulic efficiency, up to 15% faster penetration rate than closest competitor and a recommended service interval of 1000 impact hours. This means more uptime, increased productivity and lower running cost.



+ But S increases productivity at lower costs

Our new S segment boom consists of double rotation devices to ensure a fast and precise positioning with exceptional durability. Less hoses on the boom reduces downtime. Top-mounted feeds increase visibility and cross cutting functionality. That all combines to increase productivity while decreasing downtime.



+ Epiroc RCS maximizes your performance

Productivity increase with up to 15 % thanks to the latest Rig Control System. Epiroc RCS features a new intuitive interface, upgraded software and user-friendly environment simplifies the operator's work and contribute to increased productivity. Optimization of the control gives you faster boom movements, faster drilling and life times of rock drilling tools that you never seen before.



A comprehensive service offering

Even the best equipment needs to be serviced regularly to make sure it sustains peak performance. An Epiroc service solution offers peace of mind, maximizing availability and performance throughout the lifetime of your equipment. We focus on safety, productivity and reliability.

By combining genuine parts and an Epiroc service from our certified technicians, we safeguard your productivity – wherever you are.

Technical specifications

● - Standard ○ - Option

Drilling system

COP MD20	●
COP 1638HD*	○
COP 1838HD*	○
COP 2238HD*	○
Water mist flushing, external water, external or internal air supply*	○
Rock drill lubrication warning kit	●
Lubrication air filtration system	○
Hole blowing kit	○
Big hole drilling system	○
*May require a larger electrical motor	

Boom

BUT 29 HD	●
BUT S	○
Automatic lubrication for positioning unit	○

Feed

BMH 2000-Series (max 4.9 m)	●
Telescopic feed BMHT 2000-series (max 4.3 m)	○
Extension drilling set BSH 110 or BSH XS	○
Bulkhead on feeds	●
Polyuretan centalizers	●
Mining HD centalizers	○

Air/Water system

Hydraulically driven compressor Epiroc LE 10	●
Hydraulically driven screw compressor Epiroc GAR 30*	○
Hydraulic water booster pump, max capacity at 15 bar boost 200 l/min. Minimum water inlet, 2 bar at 200 l/min	●
Water hose reel including water hose	○
*Requires 2x75 kW electrical motors	

Hydraulic system

Low oil level indicator	●
Oil temperature gauge on oil tank, electronically supervised	●
Filtration 10 µm	●
Oil filter indicator	●
Extra filtration package for water- and fine particle removal	○
Mineral hydraulic oil	●
Biodegradable hydraulic oil	○
Electrical oil filling pump	●
External low placed hydraulic return filter	○
Air/oil cooler	○
Heater kit for hydraulic oil tank, diesel engine and electric motors	○
Ni-Cr plated piston rods (limitations exist)	○

Control system

Advanced Boom Control (ABC) Pure	●
Advanced Boom Control (ABC) Regular	○
Advanced Boom Control (ABC) Total	○
Measure While Drilling (MWD)	○
Underground Manager PRO (PC software)	●
Underground Manager MWD (PC software) for analysis of drill data	○
Bolt view	●
Two operator panels (for standing operation only)	○
Rig access control	●
Rig Remote Access (RRA), LAN or WLAN connection	○
Total station navigation	○
Dynamic Tunneling Package (DTP)	○

Electrical system

Total installed power 118 kW, main motors, Sf 1.15 2x55 kW***	●
Total installed power 158 kW, main motors, Sf 1.15 2x75 kW*	○
Voltage 380-1 000 V 50/60 Hz	●
Starting method, star/delta (400-690 V)**	●
Starting method, direct start (1 000 V)	●
Starting method soft start (not for 1 000 V)	○
Transformer 8 kVA	●
Electronic overload protection for electric motors	●
Digital voltmeter/amperage meter in electric cabinet	●
Percussion hour meter on operator display	●
Phase sequence and eart fault indicator	●
Cable reel, diameter 1 395 mm	●
Electric outlet for accessories, 16 A (CEI)/32 A (CE) (380-690 V)	○
Extra transformer 3-phase, 15 kVA (230/400 V outlet) (690-1 000V)	○
PC4 or PC5 Plug	○
PC4 or PC5 Connector	○
PC4 or PC5 Switch gear	○
Cable Buflex M	○
Battery charger	●
Dual controls for cable reel (and water reel)	●
Stainless steel electrical enclosure, corrosive env. pack	○

*Depending on selected options
 **Soft start standard for UL/CSA
 ***Larger powerpack is needed on altitudes 2 500 m



Carrier

Deutz TCD 3.6, Stage 3A/Tier 3, 90 kW	●
Deutz TCD 3.6, Stage V/Tier 4F, 90 kW	○
Deutz TCD 3.6, CN4, 85 kW	○
Hydrostatic transmission	●
Articulated steering ±42° steering angle*	●
Four-wheel drive	●
Electric system 24 V	●
Batteries 2x70 Ah	●
Hose/cable guiding at water/cable reel	○
Automatic differential lock on axles, limited slip	●
Tires 12.00xR20	●
Clearance outside axles 15" rear, 23" front	●
Tramming lights 24 V DC LED	●
Working lights 24 V DC LED	●
Illuminated stairs LED	●
Fuel tank, volume 95 l	●
Central lubrication system	●
Automatic lubrication system	○
Fire suppression system ANSUL (manual, checkfire or automatic)	○
Fire suppression system FORREX (automatic)	○
Rig washing kit	○
Boot washing kit	○
Manual lubrication kit (cartridges only 400 g)	○

Cabin (optional)

FOPS/ROPS certified cabin	●
Mounting height +140 mm	○
Low profile cabin -150 mm	○
Air conditioning unit, cooling only	●
12 V outlet for communication radio	○
Reversing camera with monitor	○
Fixed seat	●
Front window, 22 mm	●
Electrical heater, 1.2 kW, 230 V (CE)	○
Heating function for air conditioning (water transferred)	○
Swingable seat for drilling and tramming	○
Joystick-controlled spotlights left and right, 70 W	○
Media player	○
Cabin body made of stainless steel	○

Protective roof

Mounting height +140 mm	○
Two operator panels (for standing operation only)	○
Manual spotlight, left and right	○
Swingable seat for drilling and tramming (one operator panel only)	○

Drifter rods

Rock drill	Rod	Min. hole diameter (mm)
COP MD20	T38-H35-SR35 Speedrod	43
COP 1638HD+	T38-H35-SR35	43
COP 1838HD+	T38-R39-SR35	43
COP 2238HD+		

Extension rods for injection drilling/RAS

Rock drill	Rod	Min. hole diameter (mm)
COP MD20	R32 Speedrod	51
COP 1638HD+		
COP 1838HD+	T38 Speedrod	64
COP 2238HD+		

Shank adapters

Rock drill	Thread	Min. hole diameter (mm)
COP MD20	T38	43
COP 1638HD+	R38	43
COP 1838HD+	R32E'	51
COP 2238HD+	T38E'	64

*Intended for RAS and extension drilling with BSH 110

Couplings

Rock drill	Rod	Diameter (mm)	Length (mm)
COP MD20	R38	55	170
COP 1638HD+			
COP 1838HD+	T38	55	170
COP 2238HD+			

Recommended cable size and length 55 kw

Voltage	Type	Dimension (mm ²)	Diameter (mm)	Length (m)
380-400 V	Buflex	3x150+3G25+2x1.5	52	70
400-440 V	Buflex	3x120+3G25+2x1.5	46	110
450-550 V	Buflex	3x95+3G16+2x1.5	42	120
550-690 V	Buflex	3x70+3G16+2x1.5	37	130
1 000 V	Buflex	3x50+3G10+2x1.5	33	200

Recommendations are given for surrounding temperature of 40 °C and up to a height of 2 000 m

Recommended cable size and length 75 kw

Voltage	Type	Dimension (mm ²)	Diameter (mm)	Length (m)
380-400 V	Buflex	3x185+3G35+2x1.5	56	60
400-500 V	Buflex	3x150+3G25+2x1.5	52	70
500-550 V	Buflex	3x120+3G25+2x1.5	46	110
550-690 V	Buflex	3x95+3G16+2x1.5	42	120
1 000 V	Buflex	3x50+3G10+2x1.5	33	200

Recommendations are given for surrounding temperature of 40 °C and up to a height of 2 000 m

Noise and vibration

Operator sound pressure level in canopy, drilling, free field (ISO 11201)	104±6 dB(A) re 20 uPa
Operator sound pressure level in cabin, drilling, free field (ISO 11201)	75±3 dB(A) re 20 uPa
Operator sound pressure level working close to machine, drilling, free field	104±6 dB(A) re 20 uPa
Sound power level (ISO 3744), drilling, free field	128 dB(A) re 1p W'
Vibration levels seated, drilling (ISO 2631-1) Cabin	0.07±0.07 m/s ²
Vibration levels standing, drilling (ISO 2631-1) Cabin	0.07±0.07 m/s ²

Dimensions in millimeters

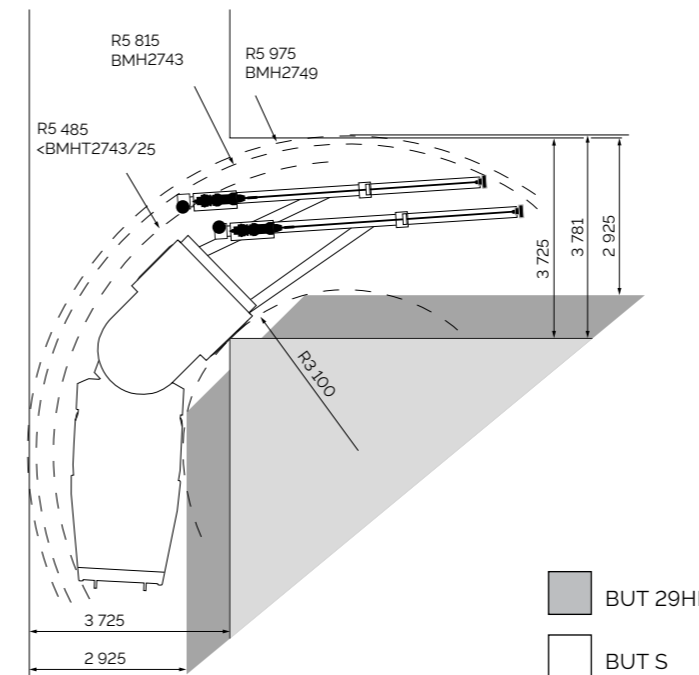
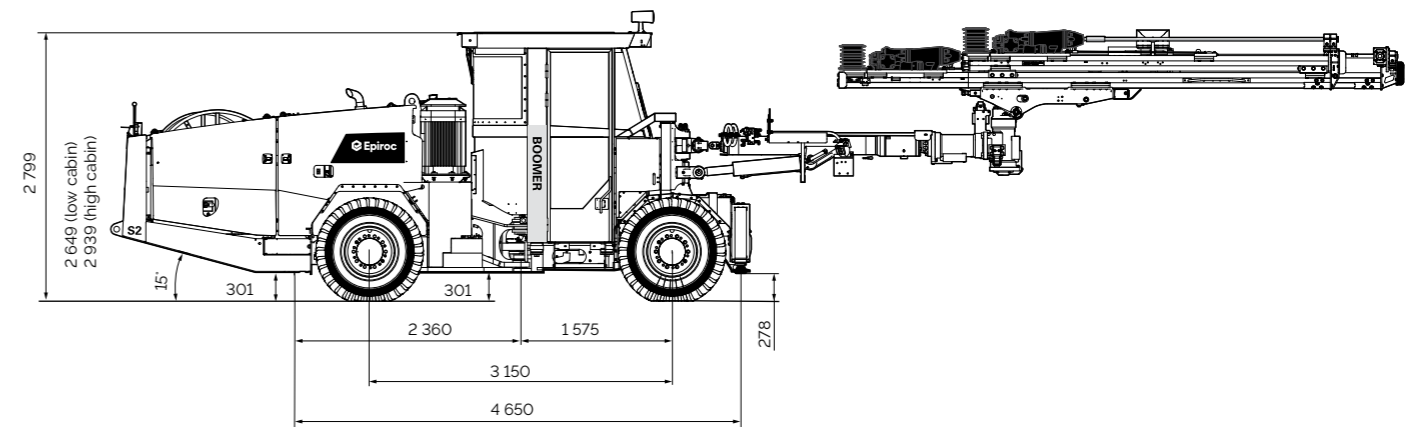

Boomer S2 turning radius.

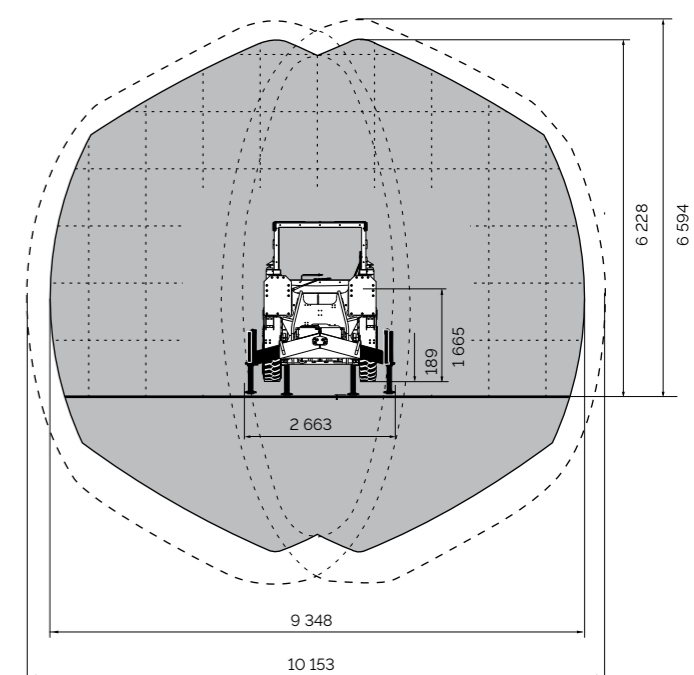

Boomer S2 coverage area.

Dimensions

Width	2 000 mm
Height with cabin	2 799 mm
Height roof up/down	2 850/2 155 mm
Length with BMH 2814 feed(s)	12 216 mm
Ground clearance	278 mm

Tramming speed

On flat ground (Rolling resistance 0.05)	>15 km/h
On incline 1:8	>5 km/h

Gross weight (depending on configuration)

Rig type	Total	Boom side	Engine side
Two boom rig	18 000-21 000 kg	11 000-12 500 kg	7 000-8 500 kg

9869 0080 01b 2022-02 Örebro, Sweden. Legal Notice © Copyright 2022. Epiroc Rock Drills AB, Örebro, Sweden. All product names in this publication are trademarks of Epiroc. Any unauthorized use or copying of the contents or any part thereof is prohibited. Illustrations and photos may show equipment with optional extras. No warranty is made regarding specifications or otherwise. Specifications and equipment are subject to change without notice. Consult your Epiroc Customer Center for specific information.



United in performance. Inspired by innovation.

Performance unites us, innovation inspires us, and commitment drives us to keep moving forward. Count on Epiroc to deliver the solutions you need to succeed today and the technology to lead tomorrow.
[epiroc.com](https://www.epiroc.com)

